

Notes:

Technology: NICHIA Automotive Grade LED

LED's: 1

Mounting: Stainless Steel Bracket

Voltage: 12vdc

Amps: 0.55A

Material: PC Lens with Hard Coating & PMMA inner Lens, Die Cast Aluminum Housing

Connection: Pigtail

Black = (Power)

White = (Ground)

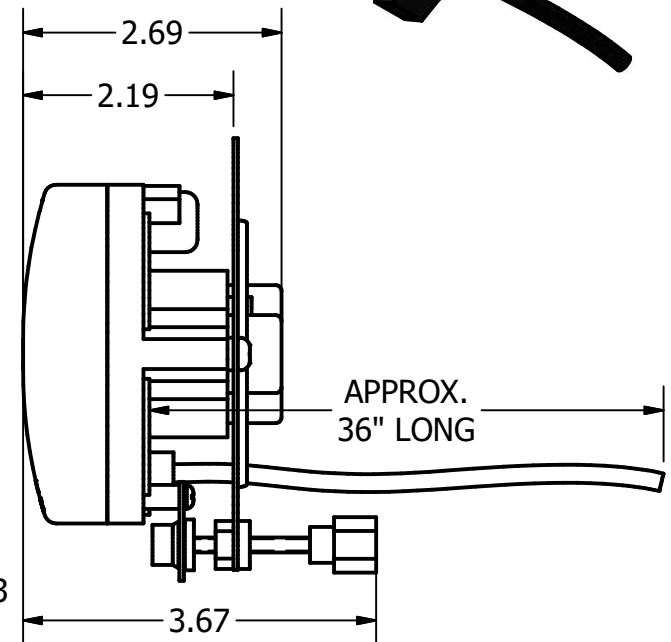
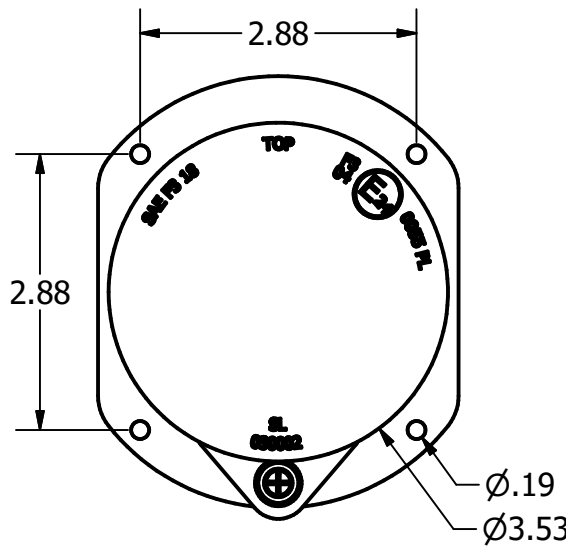
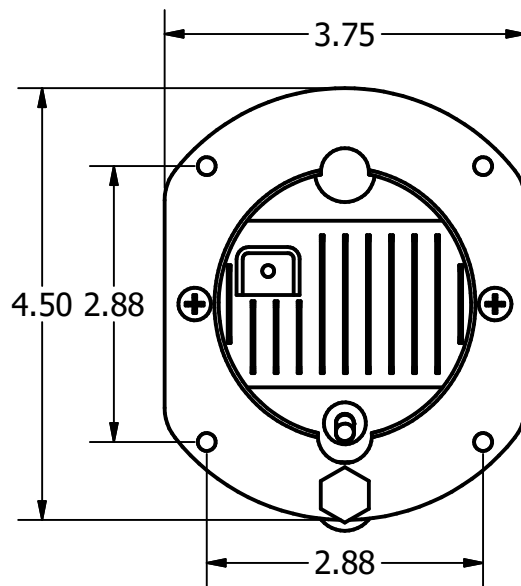
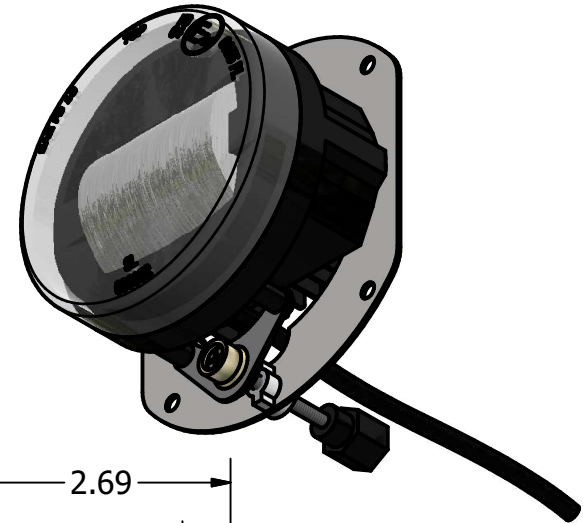
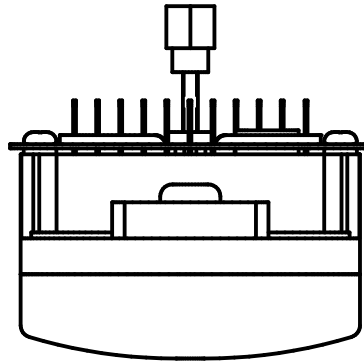

REV	DESCRIPTION	BY	DATE



DESCRIPTION: 90MM ROUND LED SAE FOG LAMP W/BRACKET - BLACK HOUSING			
PART #: 5260303		DWG #: 5260303.idw	
SCALE: NA	UNIT OF MEASURE: IN	DWG SIZE: A	NOTE:
DATE CREATED: 6-14-21	DRAWN BY: RSH	SHEET: 1	REV: