

Notes:
 Technology: Halogen
 Bulb: H9 12V 65W
 Mounting: 4-adjuster system - cloverleaf mount

Voltage: 12V
 Amps:
 Low Beam = 5.1A
 Hi Beam = 5.6A

Material:
 Lens - Polycarbonate
 Body -Aluminum + plastic mounting frame

Connection:
 3-wire weather pack H9 connector (sold separately)
 2-wire weather pack for shutter control (sold separately)

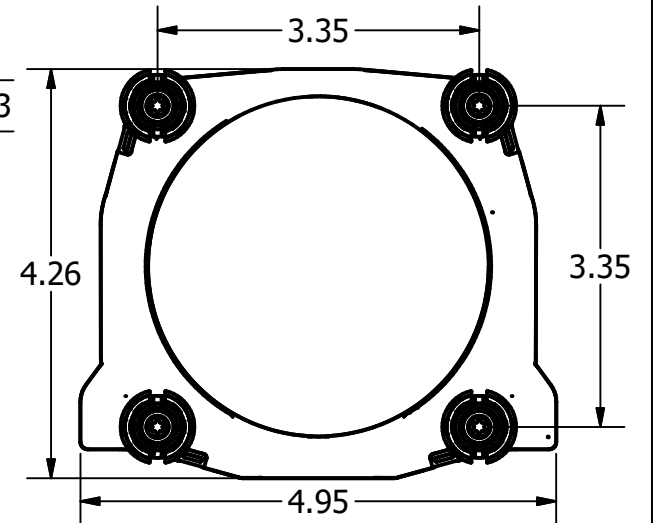
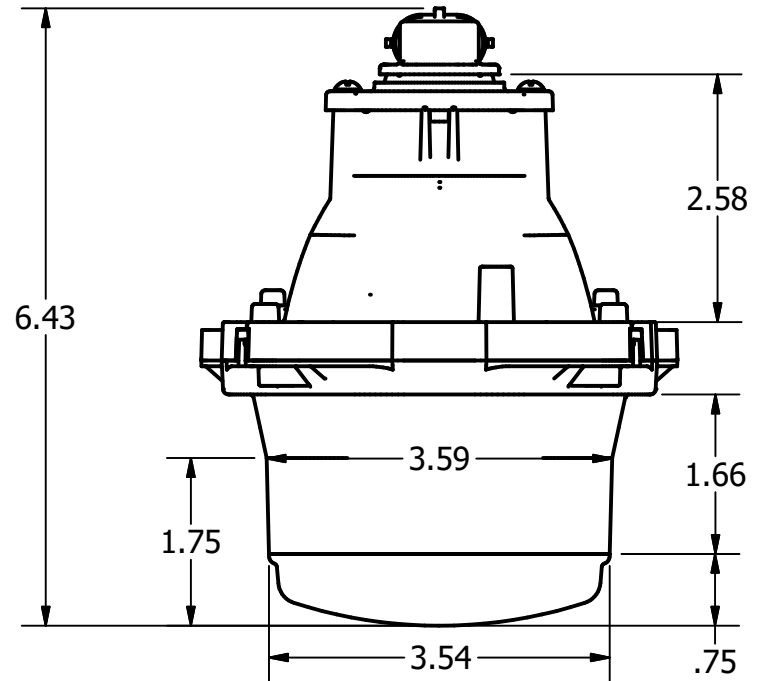
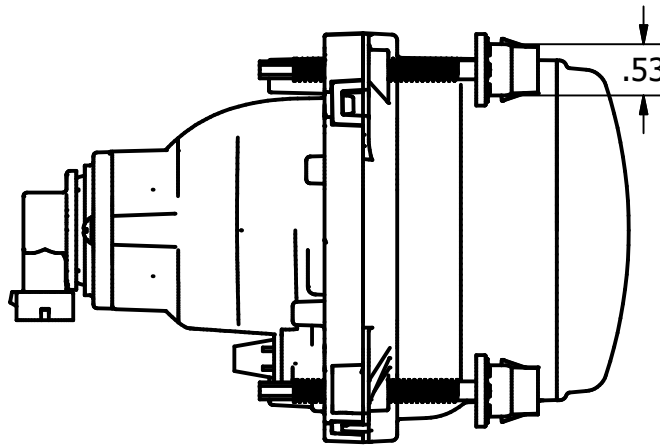
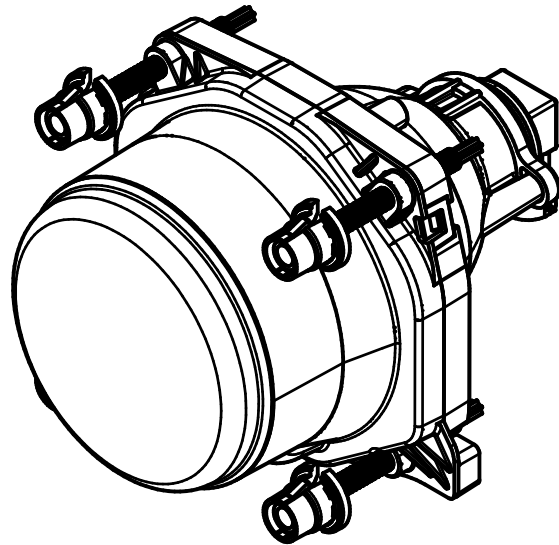

REV	DESCRIPTION	BY	DATE

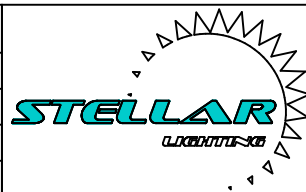

DESCRIPTION: 90mm Round Bi Halogen Headlamp			
PART #: 0180393-1		DWG #: 0180393-1	
SCALE: NA	UNIT OF MEASURE: IN	DWG SIZE: A	NOTE:
DATE CREATED: 1-28-22	DRAWN BY: RSH	SHEET: 1	REV: